

# Automatic PC On/Off for CALLISTO Data Acquisition Using Microcontroller and RTC

Vijay S. Kale<sup>1</sup>, Dnyandeve B. Patil<sup>2</sup>

Associate Professor, Department of Electronic Science, KTHM College, Nashik, Maharashtra, India<sup>1</sup>

M. Phil, Student, Department of Electronic Science, KTHM College, Nashik, Maharashtra, India<sup>2</sup>

**Abstract:** A real-time application (RTA) is an application program that functions within a time frame also called real-time computing (RTC). A real-time clock/calendar is an essential part of many computer data acquisition and control systems. The things that need to be done in specific time with accuracy can be controlled by an embedded system. Such a system provides accuracy in microsecond or Pico second. Such a system uses high speed microcontroller (On chip CPU, RAM, ROM, oscillator, Timers etc.). This paper presents designing of automatic controlling circuit for PC based data acquisition for extended-Compound Astronomical Low-cost Low-frequency Instrument for Spectroscopy and Transportable Observatory (e-CALLISTO) to operate in specific time period. Microcontroller P89v51RD2 is interfaced using I2C Protocol with Dallas real-time clock/calendar (RTC) DS1307. The interfacing circuit diagram, PCB layout, flow-chart, C program, and use of it for controlling the PC to acquire the e-CALLISTO data are described. The main advantages of a real-time clock are that it keeps track of true time independent of software execution speeds, save electricity and requirement of memory storage.

**Keywords:** Embedded system, Microcontroller, RTC, I2C protocol, Data acquisition system, Computer, CALLISTO.

## I. INTRODUCTION

There is high impact of solar activity particularly solar flares and coronal mass ejections (CMEs) on earth. It was proven that the earth weather has high impact of solar activity [1]. The solar activities are monitored by different ground new radio spectrometer. Now a day, a worldwide network extended-Compound Astronomical Low-cost Low-frequency Instrument for Spectroscopy and Transportable Observatory (e-CALLISTO) is keeping watch on different solar activities. CALLISTO network collects data located in many countries and data is made available worldwide. For full coverage of the solar radio emission, the number of stations is being connected to Callisto network using a public web interface [2].

The CALLISTO is a programmable heterodyne receiver built at ETH Zurich, Switzerland. Mainly used in applications such as observation of solar radio bursts and monitoring of RFI for astronomical science and education. The instrument operates in frequency range 45MHz and 870 MHz using a modern, commercially available broadband cable-TV tuner (CD1316) of a frequency resolution 62.5 KHz. The Flexible and Interoperable Data Transfer (FIT) files are generated up to 400 frequencies per sweep by CALLISTO that contains data and are transferred via a serial cable to a computer and saved locally. Its time resolution is 0.25 sec at 200 channels per spectrum (800 pixels per second) [3]. The RS232 connector provides connectivity to PC using serial interface RS232 protocol.

Large memory capacity storage is required to store CALLISTO data. Therefore, data acquisition in PC is to be controlled as per the need for specified time. A real-time application (RTA) is an application program that functions within a time frame that the user senses as immediate.

Whether or not a given application qualifies as RTA depends on the worst-case execution time (WCET), the maximum length of time a defined task or set of tasks requires on a given hardware platform. The use of RTAs is called real-time computing (RTC). Examples of RTAs include Video conference applications, voice over Internet Protocol, Online gaming, some e-commerce transactions, Chatting, instant messaging etc.

Automatic PC data acquisition On/Off for CALLISTO using microcontroller P89v51RD2 and real time clock (RTC) DS1307 monitors the states of PC and decides to start or stop depending on the operation need. The design gives the brief idea of interfacing of RTC to microcontroller using I2C protocol which works in master-slave configuration and keep watch on Personnel Computer (PC) by receiving status signals from PC. The circuit is designed using Philips microcontroller, a LCD of 16 character and 2 lines, a RTC DS1307 and a relay to interface PC [4, 5].

Power supply of 5v DC is used to operate circuit continuously. The automatic PC starter monitors the computer signal continuously. Checking the PC signal, PC on/off state is detected. Depending on the specified user time interval, PC is switched On/Off. In this, the PC on/off switch was controlled. The circuit is programmed using embedded 'C' language.

Once the PC is booted, then CALLISTO program is executed. All devices connected to circuit is monitored and controlled by P89v51RD2 microcontroller. The program developed for microcontroller provides great flexibility for easily modifying it for any desired time on/off operation. The block diagram is shown in Fig. 1.

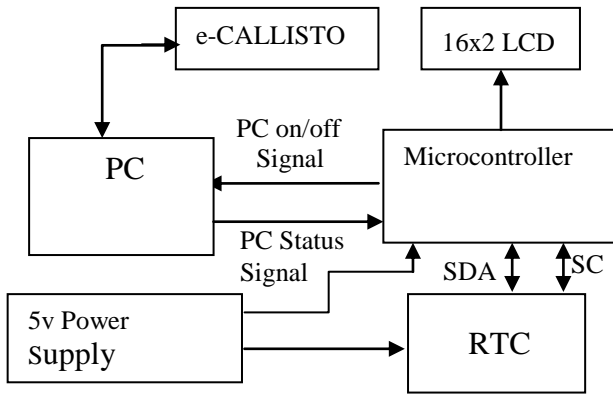

Fig.1. Block diagram of automatic PC DAS on/off system

e-CALLISTO was installed at KTHM college, Nashik, Maharashtra (India). The locations details are as follows: Latitude 20.00, Longitude 73.78 and Altitude 576 meter. CALLISTO log periodic dipole antenna (LPDA) installed is shown in Figure 2 [6, 7].



Fig2. LPDA installed on terrace of the building.

The microcontroller circuit is being used to control computer that monitor the operation of e-CALLISTO and it was controlled for day time only. Circuit takes care of PC to start at desired time and also shutdown at specific time. Presently, C program was written to start the PC at 9am and it shut down at 4pm. These timing can be changed according to the need of application.

## II. EXPERIMENTAL

The details of RTC DS1307, its control registers and I2C protocol details are as follows.

**RTC:** RTCs are present in almost every electronic device which needs to keep accurate time such as the devices personal computers, servers and embedded systems etc. The DS1307 is used to keep date, time day etc. The DS1307 Serial Real-Time Clock is a low-power, full binary-coded decimal (BCD) clock/calendar. It has 56 bytes of NV SRAM. Address and data are transferred serially via a 2-wire, bi-directional bus. The clock/calendar provides seconds, minutes, hours, day, date, month, and year information [8]. The end of the month date is

automatically adjusted for months with fewer than 31 days, including corrections for leap year. The clock operates in either the 24-hour or 12-hour format with AM/PM indicator. The RTC has a built-in power sense circuit that detects power failures and automatically switches to the battery supply. The DS1307 is an 8 pin device using an I2C interface [9]. It has 8 read/write registers that store the information is shown in Figure 3.

00H	SECONDS
	MINUTES
	HOURS
	DAY
	DATE
	MONTH
	YEAR
07H	CONTROL
08H	RAM
3FH	56 x 8

Fig. 3. RTC & RAM Memory Map

The RTC registers are located in address locations 00h to 07h. The RAM registers are located in address locations 08h to 3Fh. During a multi-byte access, when the address pointer reaches 3Fh, the end of RAM space, it wraps around to location 00h, the beginning of the clock space.

### Control Register

BIT 7	BIT 6	BIT 5	BIT 4	BIT 3	BIT 2	BIT 1	BIT 0
OUT	0	0	SQWE	0	0	RS1	RS0

### OUT (Output control):

This bit controls the output level of the square wave/Output drive (SQW/OUT) pin when the square wave output is disabled. If SQWE = 0, the logic level on the SQW/OUT pin is 1 if OUT = 1 and is 0 if OUT = 0.

### SQWE (Square Wave Enable):

This bit, when set to logic 1, will enable the oscillator output. The frequency of the square wave output depends upon the value of the RS0 and RS1 bits. With the square wave output set to 1Hz, the clock registers update on the falling edge of the square wave.

### RS (Rate Select):

These bits control the frequency of the square wave output when the square wave output has been enabled. Table 1 shows the square wave frequencies that can be selected with the RS bits [10, 11].

Table1. RS bit control and corresponding SQW output frequency

RS0	RS1	SQW Output Frequency
0	0	1Hz
0	1	4.096KHz
1	0	8.192KHz
1	1	32.768KHz

**I<sup>2</sup>C Protocol**

Philips provided a simple way to talk between IC’s by using a minimum number of pins. It becomes a recognized standard throughout the industry. Any device with the ability to initiate messages is called a ‘Master’. It might know exactly what other chips are connected, in which case it simply addresses the one it wants, or there might be optional chips and it then checks what’s there by sending each address and seeing whether it gets any response/acknowledge.

Only two chips are involved in any one communication - the Master that initiates the signals and the one Slave that responded when addressed. I<sup>2</sup>C is a serial data bus protocol that allows multiple devices to connect each other. The I2C bus uses only 2 bidirectional data lines for communicating with the microcontroller one for the serial data called serial data (SDA) and the other for synchronize clock called serial clock (SCL). The protocol uses master and slave method. The master is the microcontroller while the slave is I2C device such as Real Time Clock DS1307 [12].

**Microcontroller, LCD, PCB, and Component layout**

A Philips 89v51RD2 microcontroller is used for controlling purpose. It has 64 KB Flash memory and 1024 bytes of data RAM [13]. The Flash program memory supports both parallel programming and in serial In-System Programming (ISP) [14]. ISP programming mode is easy to program serially without using any extra hardware. A 16x2 LCD is used to display date, time and PC status [15].

Figure 4 gives the interfacing of microcontroller P89vRD2 and RTC DS1307. Microcontroller P2.0 and P2.1 pins are used for SDA and SCL of DS1307. PC is monitored using the controller pin P3.4. Microcontroller P0 port used for data lines and control pins are used of P2 port.

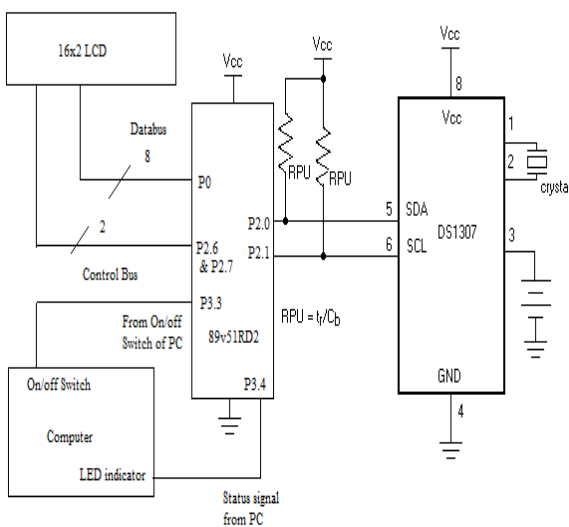

Fig.4. Interfacing diagram of microcontroller, RTC, PC and LCD

PCB layout of microcontroller and RTC is shown in Figure 5. Figure 6 shows the component layout.

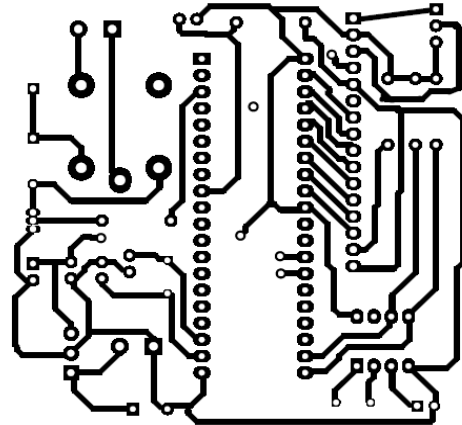

Fig.5 PCB Layout of microcontroller and RTC

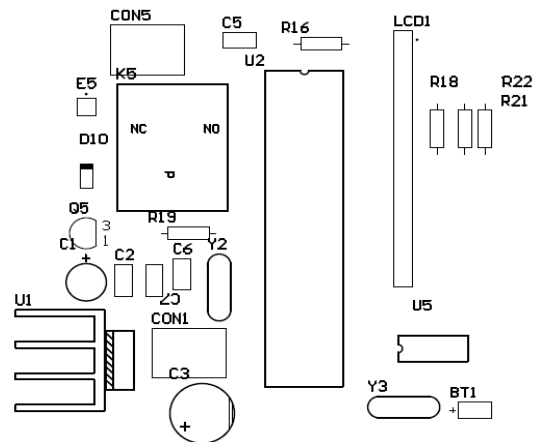

Fig.6 PCB Layout of microcontroller and RTC

**III.FLOW CHART**

The flow chart of automatic PC data acquisition On/Off for CALLISTO Using Microcontroller and RTC is shown in Figure 7.

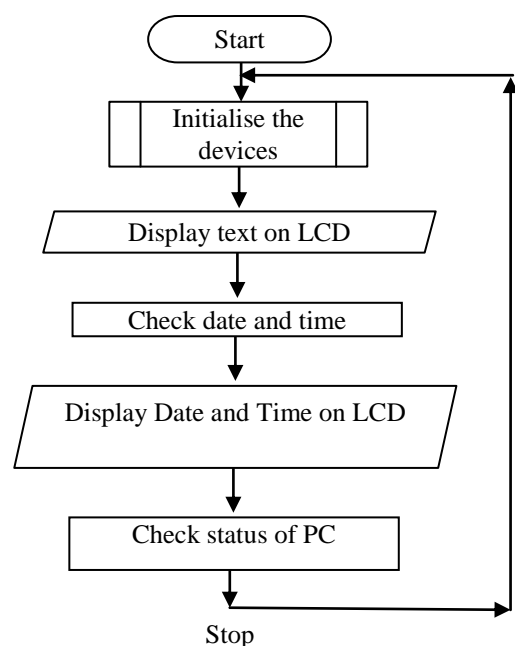

Fig.7. Flow-chart of automatic PC data acquisition On/Off

The detail flowchart of RTC is shown in Figure 8.

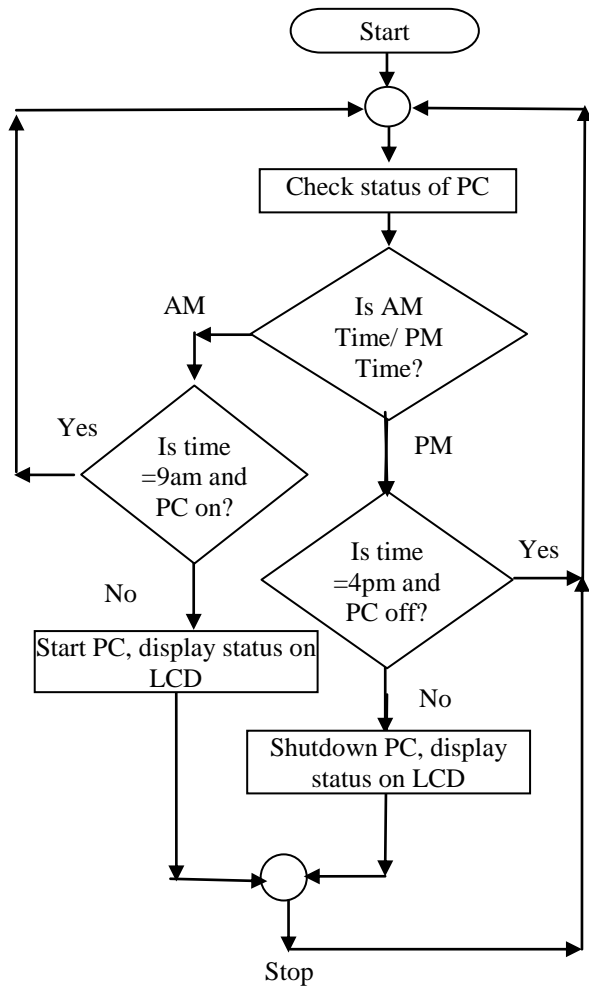

Fig.8. Flow-chart of detail steps of PC and real time clock

#### IV. C LANGUAGE PROGRAM

```

#include "DS1307.h"
#include "I2C.h"
#include "LCD.h"
sbit sw = P3^3;
sbit PcOnFlag= P3^4;
void Status( unsigned char*);
void PC_Status(unsigned char*);
// Main function
void main()
{
    InitLCD(); // Initialize LCD
    InitI2C(); // Initialize i2c pins
    PcOnFlag=1;
    WriteCommandToLCD(0x84);
    WriteStringToLCD("Computer ");
    WriteCommandToLCD(0xC2);
    WriteStringToLCD("Auto Starter ");
    delay(400);
    Status(Get_DS1307_RTC_Date());
    WriteCommandToLCD(0x01);
    while(1)
    {
        PC_Status(Get_DS1307_RTC_Time());
  
```

```

// Display RTC time on first line of LCD
DisplayTimeToLCD(Get_DS1307_RTC_Time());
// Display RTC date on second line of LCD
DisplayDateOnLCD(Get_DS1307_RTC_Date());
}
}

void Status( unsigned char* dateArray )
{
    if(dateArray[3]==0)
    {
        // Set initial time
        Set_DS1307_RTC_Time(AM_Time, 7, 00, 00);
        // Set time 07:00:00 AM
        // Set initial date
        Set_DS1307_RTC_Date(29, 1, 16, Tuesday);
        // Tue 29-01-2016
    }
}

void PC_Status(unsigned char* timeArray)
{
    switch(timeArray[3])
    {
        case AM_Time:
            if(timeArray [2]>=0x09)
            {
                if (PcOnFlag==0)
                {
                    sw=0;
                    WriteCommandToLCD(0x01);
                    WriteCommandToLCD(0x84);
                    WriteStringToLCD("Computer ");
                    WriteCommandToLCD(0xC4);
                    WriteStringToLCD("Started");
                    delay(400);
                    sw=1;
                    WriteCommandToLCD(0x01);
                    return;
                }
            }
            break;

            case PM_Time: if(timeArray [2]==0x04)
            {
                if (timeArray [1]==30)
                {
                    if(PcOnFlag==1)
                    {
                        sw=0;
                        WriteCommandToLCD(0x01);
                        WriteCommandToLCD(0x83);
                        WriteStringToLCD("Windows is");
                        WriteCommandToLCD(0xC2);
                        WriteStringToLCD(" Shutting down"); delay(400);
                        sw=1;
                        WriteCommandToLCD(0x01);
                        return;
                    }
                }
            }
  
```



```

return;
}
return;
}
break;
default: break;
}
}
}

```

### V. RESULT

The photograph of the working system is shown in Figure 9.



Fig. 9. Data acquisition system with control circuit and CALLISTO

It includes the PC, controller circuit and CALLISTO. PC monitor screen shows the real time data acquisition of solar radiations using CALLISTO. Using Keil uVision software, C language program was developed and using ISP it was burned in microcontroller. The program was written to control a day data acquisition of CALLISTO from 9am to 4pm. The information displayed on control circuit of date, time AM/PM is shown in Figure 10.



Fig10. LCD display connected to RTC shows time, date and day.

LCD display shows the time 10:19:12 AM, Date 08/05/2016 and day Sunday. At 4PM PC will automatically shut down and next day it will automatically starts the CALLISTO program at 9am.

### VI. CONCLUSION

The automatic controlling circuit for PC based data acquisition for extended-Compound Astronomical Low-cost Low-frequency Instrument for Spectroscopy and Transportable Observatory (e-CALLISTO) to operate 9am to 4pm was developed and implemented. It is working successfully. It includes Philips microcontroller P89V51RD2 which is programmed and using I2C Protocol with Dallas real-time clock/calendar (RTC) IC 1307 in such a way so as to maintain real timing and same is displayed on 16X2 LCD.

Presently the system monitors and controls the CALLISTO data acquisition. Using the same system or slight modifications, user can monitor and control different application software or appliances. The main advantage of a real-time clock is that it keeps track of true time independent of software execution speeds. Such type of system will reduce the unnecessary working of the system. This will ultimately save the electricity and memory storage.

### ACKNOWLEDGMENT

This research is supported by the Principal **Dr. Dilip Dhondge** and Head, Department of Electronic Science, **Dr. M. B. Matsagar** of KTHM College, Nashik, Maharashtra, India.

### REFERENCES

- [1] N.Gopalswamy, A Global picture of CMEs in the Inner Heliosphere G. Poletto, Suess, S.T. (Ed.), Astrophysics and Space Science 2004, PP. 201-251.
- [2] Z. S. Hamidi, N. N. M. Shariff, "Monitoring at Different Types of Bursts Associated with Solar Flare Phenomenon, Thermal Energy and Power Engineering", Vol. 3, Issue 1, Feb 2014, PP. 181-184.
- [3] [http://www.e-callisto.org/GeneralDocuments/ Callisto-General/ P89v51RD2\\_datasheet,](http://www.e-callisto.org/GeneralDocuments/Callisto-General/P89v51RD2_datasheet.pdf) Philips Corporation, [www.datasheet catalog.com/datasheets\\_ pdf/P/8/.../P89V51RD2.shtml](http://www.datasheetcatalog.com/datasheets_pdf/P/8/.../P89V51RD2.shtml)
- [4] Sadeque Reza Khan, Alvir Kabir, Dilshad Ara Hossain, "Designing Smart Multipurpose Digital Clock using Real Time Clock (RTC) and PIC Microcontroller", International Journal of Computer Applications (0975 – 8887) Volume 41– No.9, March 2012
- [5] C. A. Balani, "Antenna Theory- Analysis and Design", 3rd ed., a John Wiley & Sons, Inc. Publication, 2005.
- [6] Notes on LPDA stubs. [Online]. Available: <http://www.cebik.com/lpda/1st.html>
- [7] DS1307 RTC Real time clock mini-breakout. [Online]. Available: (2012)<http://www.ladyada.net/learn/breakoutplus/ds1307rtc.html>.
- [8] DS1307 64 x 8 Serial Real-Time Clock datasheet," Dallas Semiconductor. [http://html.alldatasheet.com/html-pdf/58481 /DALLAS/DS1307/735/4/DS1307.html](http://html.alldatasheet.com/html-pdf/58481/DALLAS/DS1307/735/4/DS1307.html).
- [9] Display Real Time Clock (RTC) On LCD, 5 February 2012.Avaliable:[http://www.cytron.com.my/attachment/Details%20 Description/PR12%20v4.pdf](http://www.cytron.com.my/attachment/Details%20Description/PR12%20v4.pdf)
- [10] I2C Protocol-How it Works, And What To Watch Out For [Online]. Available: <http://www.i2cprotocol.com/>. (2010)
- [11] Sagar. G. Yadav, K. A. Narayanankutty, "A Versatile Industrial Timer and Real Time Keeper", Wireless Engineering and Technology, 2011, 2, 196-203.
- [12] Muhammed Ali Mazidi, Janice GillispieMazidi, Rolin D.

Mcklinlay, The 8051 Microcontroller and Embedded Systems Using Assembly and C, 2nd ed., Pearson Prentice Hall, pp. 407-429, 2009.

- [14] Interfacing the DS1307 with an 8051-Compatible Microcontroller. Available: <http://www.maximintegrated.com/app-notes/index.mvp/id/95>. (2001)
- [15] Interfacing LCD to 8051. [Online]. Available: <http://www.dnatec.hindia.com/Tutorial/8051-Tutorial/Interfacing-LCD-to-8051.html>. (2011)

### BIOGRAPHIES



**Vijay Kale** (M.Sc, M.Phil, Ph.D, PGDIM, ADCSSA) is working as Assistant Professor (Department of Electronic science, KTHM College, Nashik, Maharashtra, India). He has been in the teaching profession (UG and PG) since last 27 years. He has been

presented research paper in international conferences (USA, Bangkok). He published research papers in national and international journals. He received R. Chandrasekhar award from Indian Physics Association (IPA), Savitribai Phule Pune University. He has written five books. He worked as project guide for M.Sc. (Electronic Science) and research guide to M. Phil. students. He has worked on several academic committees of Savitribai Phule Pune University. He has worked as a resource person in refresher course, workshop etc. He is presently working on ARM microcontroller based sensor application, Wireless sensor application, e-CALLISTO etc.



**Dnyandev Patil** is working as M. Phil. student (Department of Electronic science, KTHM College, Nashik). His research activity is in antenna designing and Sensor based embedded system. He had completed project entitled Smart Energy Meter and Wind Speed

Measurement using microcontroller. Presently He is working on e-CALLISTO.