



Detection of Carbon Monoxide Gas in Atmosphere

Shete Sarika Vijay¹, Prof R.P. Chaudhari²

Dept. of E&TC Engineering, Government College of Engineering, Aurangabad, Maharashtra, India^{1,2}

Abstract: This paper presents design of Carbon Monoxide (CO) gas detector based on microcontroller performance. The device is embedded with real-time measurement through visualization in Liquid Crystal Display (LCD). In addition, the data processing utilizes microcontroller PIC16F877. A under programming environment of Keil Compiler. The visualization itself is designed based on the combination between programming language of Microsoft Visual Basic ver. 6.0 and C. Data transmission can be very flexible in this case due to the capability standard of microcontroller for communication networks. Also, for one day measurement, the data can be simple stored inside the device. The device has been initially tested in the laboratory on several physical data output. In the implementation, the device has been used to measure the CO level on different locations, such as indoor and outdoor testing and it has shown proper results of measurement. The system works with sensor which continuously monitor the temperature, and leakage of co gas. According to threshold set the respective parameter controls the electrical devices. From PUC and our sensor received same percentage of emission of co gas and this calibrated with our system. The output through two wheeler and four wheeler and it is found that by implementing this system the emission of co gas can be minimized up to permissible limit. All these observations of the system are listed below.

Keywords: Carbon Monoxide (CO), microcontroller, PIC16F877A, Keil Compiler, Microsoft Visual Basic and C.

I. INTRODUCTION

A carbon monoxide detector or CO detector is a device that detects the presence of the carbon monoxide (CO) gas in order to prevent carbon monoxide poisoning. In the late 1990s Underwriters Laboratories (UL) changed their definition of a single station CO detector with a sound device in it to a carbon monoxide (CO) alarm. This applies to all CO safety alarms that meet UL 2034; however for passive indicators and system devices that meet UL 2075 UL refers to these as carbon monoxide detectors. This difference is not well known by the public. CO is a colorless, tasteless and odorless compound produced by incomplete combustion of carbon containing materials.

It is often referred to as the "silent killer" because it is virtually undetectable without using detection technology and most do not realize they are being poisoned. Elevated levels of CO can be dangerous to humans depending on the amount present and length of exposure. Smaller concentrations can be harmful over longer periods of time while increasing concentrations require diminishing exposure times to be harmful.

CO detectors are designed to measure CO levels over time and sound an alarm before dangerous levels of CO accumulate in an environment, giving people adequate warning to safely ventilate the area or evacuate. Some system-connected detectors also alert a monitoring service that can dispatch emergency services if necessary.

While CO detectors do not serve as smoke detectors and vice versa, dual smoke/CO detectors are also sold. Smoke detectors detect the smoke generated by flaming or smoldering fires, whereas CO detectors detect and warn people about dangerous CO buildup caused, for example, by a malfunctioning fuel-burning device. In the home, some common sources of CO include open flames, space heaters, water heaters, blocked chimneys or running a car inside a garage. Carbon monoxide (CO) is a colorless, odorless, and tasteless gas that is slightly lighter than air. It is toxic to humans and animals when encountered in higher concentrations, although it is also produced in normal animal metabolism in low quantities, and is thought to have some normal biological functions. In the atmosphere it is spatially variable, short lived, having a role in the formation of ground-level ozone. CO detectors can be placed near the ceiling or near the floor because CO is very close to the same density as air.

Since CO is colorless, tasteless and odorless (unlike smoke from a fire), detection in a home environment is impossible without such a warning device. It is a highly toxic inhalant and attaches to the hemoglobin (in the blood stream) with an affinity 200x stronger than oxygen, producing inadequate amounts of oxygen traveling through the body.

a) Hazards Due to Carbon Monoxide

To explain this aspect, we need to explain how the body uses oxygen from the air. Oxygen is transported around the body via the red blood cells. Specifically, oxygen binds to a substance within the red blood cells called Haemoglobin, which is also responsible for their red color.



Haemoglobin takes up oxygen as blood passes through the lungs, and at the same time carbon dioxide, produced by the body's metabolism, is released from the blood into the exhaled breath. The combination of oxygen with haemoglobin is called oxyhaemoglobin and this 'oxygenated' blood is carried away from the lungs through the bloodstream to all the tissues of the body.

Carbon monoxide can also bind to haemoglobin but does so about 240 times more tightly than oxygen, forming a compound called carboxyhaemoglobin. This means that if both carbon monoxide and oxygen are inhaled, carbon monoxide will preferentially bind to haemoglobin. This reduces the amount of haemoglobin available to bind to oxygen, so the body and tissues become starved of oxygen.

Carboxyhaemoglobin also has direct effects on the blood vessels of the body - causing them to become 'leaky'. This is seen especially in the brain, causing the brain to swell, leading to unconsciousness and neurological damage.

One of the difficulties with diagnosing carbon monoxide poisoning is that many of its symptoms are similar to those of other conditions. Often the onset of symptoms is gradual, occurring without the individual or doctor being fully aware of what is happening.

II. BRIEF HISTORY OF THE SYSTEM

The Literature survey was conducted for dissertation in all possible means through media of textbooks, reference books, and data books and Internet. A sensor is a device that measures a physical quantity and converts it into an equivalent analog or digital signal which can be read by an observer or by an instrument. Monitoring of an indoor environment involves sensing the changes occurring inside it.

In the late 1990s Underwriters Laboratories (UL) changed their definition of a single station CO detector with a sound device in it to a carbon monoxide (CO) alarm. This applies to all CO safety alarms that meet UL 2034; however for passive indicators and system devices that meet UL 2075 UL refers to these as carbon monoxide detectors.

Aristotle (384–322 BC) first recorded that burning coals emanated toxic fumes. An ancient method of execution was to shut the criminal in a bathing room with smoldering coals. What was not known was the mechanism of death.

Galen (129–199 AD) speculated that there was a change in the composition of the air which caused harm when inhaled [6]. In 1776, the French chemist de Lassone produced CO by heating zinc oxide with coke, but mistakenly concluded that the gaseous product was hydrogen, as it burned with a blue flame. The gas was identified as a compound containing carbon and oxygen by the Scottish chemist William Cumberland Cruikshank in the year 1800. Its toxic properties on dogs were thoroughly investigated by Claude Bernard around 1846 [7].

During World War II, a gas mixture including carbon monoxide was used to keep motor vehicles running in parts of the world where gasoline and diesel fuel were scarce. External (with a few exceptions) charcoal or wood gas generators were fitted, and the mixture of atmospheric nitrogen, carbon monoxide, and small amounts of other gases produced by gasification was piped to a gas mixer. The gas mixture produced by this process is known as wood gas. Carbon monoxide was also used on a small scale during the Holocaust at some Nazi extermination camps, the most notable by gas vans in Chelmno, and in the Action T4 "euthanasia" program [8].

A carbon monoxide detector or CO detector is a device that detects the presence of the carbon monoxide (CO) gas in order to prevent carbon monoxide poisoning. In the late 1990s Underwriters Laboratories (UL) changed their definition of a single station CO detector with a sound device in it to a carbon monoxide (CO) alarm. This applies to all CO safety alarms that meet UL 2034; however for passive indicators and system devices that meet UL 2075, UL refers to these as carbon monoxide detectors. CO is a colorless, tasteless and odorless compound produced by incomplete combustion of carbon-containing materials. It is often referred to as the "silent killer" because it is virtually undetectable without using detection technology and, in a study by Underwriters Laboratories, "Sixty percent of Americans could not identify any potential signs of a CO leak in the home". Elevated levels of CO can be dangerous to humans depending on the amount present and length of exposure. Smaller concentrations can be harmful over longer periods of time while increasing concentrations require diminishing exposure times to be harmful.

CO detectors are designed to measure CO levels over time and sound an alarm before dangerous levels of CO accumulate in an environment, giving people adequate warning to safely ventilate the area or evacuate. Some system-connected detectors also alert a monitoring service that can dispatch emergency services if necessary. (CO) detectors are devices that monitor the amount of CO in the air over a given time period. Distinguished by their sensing technology, three basic types of CO detectors are used today: biomimetic, metal oxide semiconductor, and electrochemical.

While CO detectors do not serve as smoke detectors and vice versa, dual smoke/CO detectors are also sold. Smoke detectors detect the smoke generated by flaming or smoldering fires, whereas CO detectors detect and warn people about dangerous CO build-up caused, for example, by a malfunctioning fuel-burning device. In the home, some common sources of CO include open flames, space heaters, water heaters, blocked chimneys or running a car inside a garage.



III.SYSTEM DEVELOPMENT

In this system we are measuring the atmospheric CO (Carbon Monoxide) concentration using embedded system and displaying it on 16 x 2 alphanumeric displays. The complete system is battery operated. For detection of carbon monoxide we are using MQ-7 Gas sensor. For calibration purpose we took readings of different vehicles at PUC station, by PUC unit and our unit. We compared the result of both devices and observed to be almost same. The main aim of in this paper is to measure the concentration of Carbon monoxide gas and display it on LCD. From the readings we have to calibrate our system with standard CO measurement system. The main aim is to make the system portable and easy to use. So here is the block diagram of the system that we are supposed to design to measure CO concentration in air.

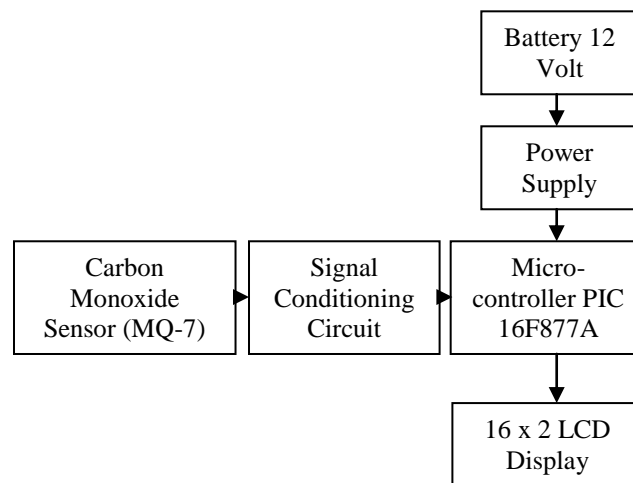

Fig. 1: Functional Block Diagram of the System

A. CO Sensor (MQ - 7)

CO Sensor is the main unit of our system which senses the concentration of CO Sensor. We are using MQ-7 CO sensor. This sensor have carbon monoxide sensing SnO₂ metal layer. Which changes its resistance when CO gas is sensed. This change in resistance is converted into change in voltage. And hence we get variable voltage to output of sensor pin.

B. Signal Conditioning Circuit

The output from the sensor pin is not compactible to actual CO concentration level. So to convert this signal level to measurable CO concentration level, we have to use signal conditioning circuit which is nothing but a simple resistor combination arrangement. This circuit converts sensor signal into measurable form of voltage, which is then given to ADC of the microcontroller.

C. Microcontroller PIC16F877A

In microcontroller section, we are processing actual analog signal in digital form and doing calculation part. The signal from Signal conditioning circuit, is given to ADC of the microcontroller unit. ADC converts the analog signal from Sensor into digital signal and given for further processing. Using formula we are converting this digital signal to CO concentration level and display the concentration on LCD display. Microcontroller unit controls all the input and output devices and does the processing on data.

D. 16 x 2 LCD Display

16 x 2 alphanumeric LCD display is connected to microcontroller unit to display the messages and readings of the CO sensor. It receives the ASCII characters which it gets from microcontroller unit. In microcontroller we have to convert integer or decimal values to ASCII values to get properly displayed on LCD. It has 2 lines of 16 characters each.

E. Battery with Power Supply

To make complete system portable, we are using battery source. A lead acid battery of capacity 12V & 7Ah is connected to the system to source the power to the complete circuit. By taking 12V input we are regulating it to 5V to make our system work, as all electronic components works on 5V supply.



F. MQ-7 Sensor



Fig. 2: MQ-7 Sensor

Features

- * High sensitivity to carbon monoxide
- * Stable and long life

Specifications

- Surface resistance of sensitive body-2-20k
- Concentration slope rate Less than 0.5
- Standard working condition-Temperature $-20^{\circ}\text{C}\pm 2^{\circ}\text{C}$ relative humidity $65\%\pm 5\%$ RL:10 K $\Omega \pm 5\%$ Vc:5V $\pm 0.1\text{V}$ VH:5V $\pm 0.1\text{V}$ VH:1.4V $\pm 0.1\text{V}$
- Preheat time No less than 48 hours Detecting range: 20ppm-2000 ppm carbon

G. LCD Display

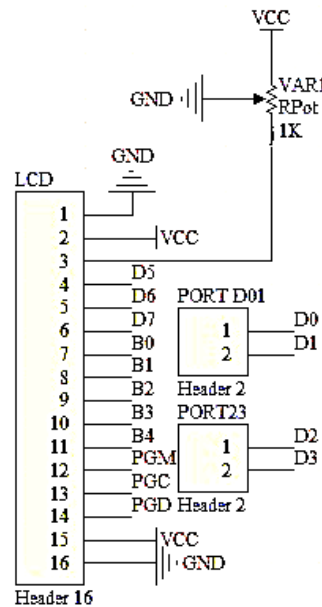

Fig. 3: LCD Display Section

In this section we have connected 16 pin LCD Display to Port B (pin 7 to pin 14) and Control lines of LCD i.e. rs, rw, en (pin 4, pin 5, pin 6 resp.) to port pins D5, D6, D7 respectively. Variable resistor VAR1 of 1KOhm to set contrast of the LCD & connected to pin 3 of LCD. Pin 1 & pin 16 are connected to GND signal and Pin 2 & Pin 15 are connected to VCC signal.

H. Microcontroller Section

The basic circuit of microcontroller PIC16F877A. This microcontroller is having 4 complete ports namely PORTA, PORTB, PORTC, PORTD; and 3 pins of PORTE. PORTA & PORTE acts as analog ports and all other are digital I/O



International Journal of Innovative Research in Electrical, Electronics, Instrumentation and Control Engineering

ISO 3297:2007 Certified

Vol. 5, Issue 5, May 2017

ports. In this circuit, pull up resistor R1 is connected to reset pin (MCLR) of microcontroller, this circuit gives the starting pulse to the microcontroller.

IV. SOFTWARE DESCRIPTION

The keil C51 C compiler for the 8051 microcontroller is used to solve the complex problems facing embedded software developers. It provides more features than any other 8051 C compiler available today. The microcontroller applications that are written in C and once compiled using the C51 compiler have the efficiency and speed of the assembly language. While starting a new project, first we have to select the microcontroller, that we are going to use for our project from the device database and the μ Vision IDE sets all compiler, assembler, linker, and memory options.

There are several different ways of writing code for embedded systems depending on the complexity of the system and the amount of time and the money that can be spent. Developing software for ready-built hardware is generally easier than for discrete designs. Many ready built designs provide libraries and additional software support which dramatically cut the development time. The traditional method of writing code has centered on a two pronged approach based on the use of microprocessor emulation. The Embedded software development steps are shown in figure.

The Embedded software is actually written, compiled, assembled, linked, debugged and tested at the host system. Then the software is downloaded in to the Atmel 89c51 Microcontroller using the universal programmer.

The universal programmer is connected with the host system through the RS232 serial port communication. The microcontroller is removed from the universal programmer socket and then the microcontroller is placed in to the embedded target system.

The Embedded software development and testing were usually done at the host system rather than the target system, since the target system may not have a keyboard, screen, disk drive and the other peripherals necessary for programming. The embedded computing machines make their design more difficult due to complex testing, limited observability and controllability and also with restricted development environments.

V. PERFORMANCE ANALYSIS

The system works with sensor which continuously monitor the temperature, and leakage of co gas. According to threshold set the respective parameter controls the electrical devices.

From PUC and our sensor received same percentage of emission of co gas and this calibrated with our system. The output through two wheeler and four wheeler and it is found that by implementing this system the emission of co gas can be minimized up to permissible limit.

TABLE I OBSERVATIONS

Sr. No.	Date	Two Wheeler Exhaust readings in 5 step Acceleration	GAS Conc. In % from PUC machine	GAS Conc. In % from Project Equipment
1	2/5/2017	Vehicle No MH-12 KU-7637	0.03%	0.13%
2	2/5/2017	Vehicle No MH-12 KU-7637	1.06%	1.42%
3	2/5/2017	Vehicle No MH-12 KU-7637	1.12%	1.13%
4	2/5/2017	Vehicle No MH-12 KU-7637	1.27%	1.30%
5	2/5/2017	Vehicle No MH-12 KU-7637	1.8%	1.10%



Fig.4.PUC Booth



Fig.5. Readings



Fig.6. System development

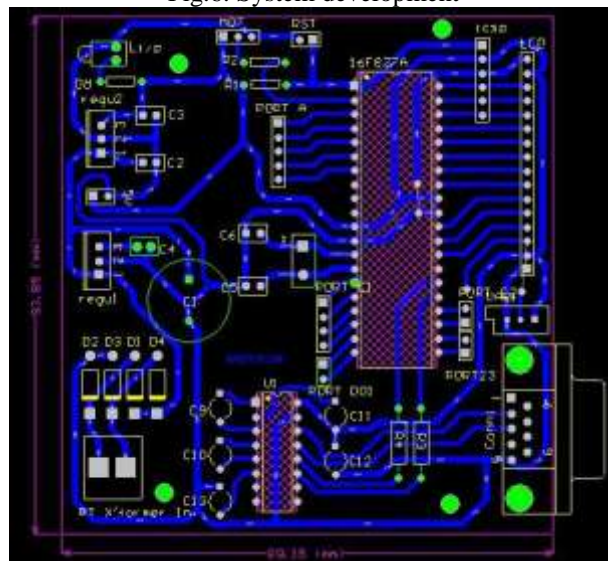

Fig.7. PCB Layout



Fig.8. Testing of CO of Vehical



Fig.9. Actual System



Fig.10. Actual demonstration

VI. CONCLUSIONS

An embedded system is designed and tested for toxic gas detection inside in different environment using PIC16F877A microcontroller. Toxic gas like CO is less sensible by human which endangers the human lives. This critical situation can be avoided by implementing the sensors for sensing the level of CO and temperature level and is displayed. Ventilation is immediately provided in the cabin, whenever this critical situation occurs.

This prototype can also be used at Home; Educational and working institutions for monitoring the indoor air quality which intern enhance the quality of working environment. Thus from CO gas detection using microcontroller We conclude that, using such type of gas detection we can measure the level of carbon monoxide in vehicles and industries.

REFERENCES

- [1] Kavi K. Khedo, et.al: 'A Wireless Sensor Network Air Pollution Monitoring System', International Journal of Wireless & Mobile Networks 2.2, 2010, pp. 31-45
- [2] J. Air et al., Ontario exposure assessment study: Design and methods validation of personal, indoor, and outdoor air pollution monitoring, Journal of Air Waste Management Association, vol.61, no.2, pp.142-156, 2011.
- [3] S. S. Ram et.al: 'SEMEDS: An important tool for air pollution bio-monitoring', Micron, In Press 2011.
- [4] Yong Su Kim et.al: 'Predictive monitoring and diagnosis of periodic air pollution in a subway station', Journal of Hazardous Materials, Vol. 183, (1-3), 2010, pp. 448-459
- [5] Eliza Bradley, Ira Leifer and Dar Roberts: 'Long-term monitoring of a marine geologic hydrocarbon source by a coastal air pollution station in Southern California', Atmospheric Environment, Vol. 44 (38), 2010, pp. 4973-4981
- [6] Datasheet MQ-6 Semiconductor Sensor for LPG, 2-4.
- [7] Health, E., & Elements, L. (2012). Liquefied Petroleum Gas (Canada) Section 1: Identification of the substance or mixture and of the supplier 59 Section 2: Hazard (s) Identification Section 3: Composition / Information on Ingredients Section 4: First Aid Measures, 1-8.
- [8] <http://unfccc.int/resource/convkp.html>
- [9] http://en.wikipedia.org/wiki/carbon_monoxide.html
- [10] http://coconundra.info/CO_Levels.php
- [11] www.alldatasheet.com
- [12] www.microchip.com