

# Mechatronic Design And Robust Control of An Artificial Ventilator In Response To The COVID-19 Pandemic

Sivagama Sundari.P<sup>1</sup>, Jerson Fenadict Andro.A.M<sup>2</sup>, Kadhirmeni.S<sup>3</sup>, Kamalakannan.K<sup>4</sup>,  
Manikandan.R<sup>5</sup>

Associate Professor, Electronics and Communication Engineering, Saranathan College of Engineering, Trichy<sup>1</sup>

Student, Electronics and Communication Engineering, Saranathan College of Engineering, Trichy<sup>2,3,4,5</sup>

**Abstract:** The emergency coming about because of the COVID19 pandemic has created an unfriendly circumstance in which great many individuals kicked the bucket because of counterfeit ventilation devices. The primer plan of a straightforward, simple to-utilize, and simple to-construct ventilator with a novel plan that can be utilized for COVID-19 patients in crises and to forestall monstrous death toll in asset poor environments. Human lungs utilize the converse tension produced by the constriction movement of the stomach to suck in air for breathing. A problematic movement is utilized by a ventilator to swell the lungs by siphoning type movement. We here plan and foster utilizing Node-MCU enveloping this multitude of prerequisites to foster a dependable yet reasonable ventilator to help in the midst of pandemics. The whole framework is driven by an ARDUINO regulator to accomplish wanted results and to help patients in COVID pandemics and other crisis circumstances.

**Keywords:** SPO2 Sensor, Heartbeat Sensor, Temperature Sensor (LM35), Arduino UNO, Nebulizer Pump.

## I. INTRODUCTION

Respiratory illnesses and disappointments are a significant general medical problem in both created and creating countries. This worldwide issue has been enormously complemented by the COVID-19 pandemic, which has brought about a dire requirement for additional ventilators. Indeed, even created nations like Spain, Italy, and the United States are experiencing a lack of these costly respiratory gadgets which likewise demand a generally lengthy investment to produce them. There are two kinds of ventilator gadgets. One sort just drives a specific volume of air into the lungs precisely without representing whether the patient needs to bring air into their body or to push air out. Practically these gadgets depend on the utilization of the ordinary pack valve veil (BVM). A BVM is a plastic pack that a clinical consideration professional can flatten physically with their hands, and hence gives a cheap and simple method for constraining air into the lungs. Indeed, BVMs are applied by specialists on call for patients who are not breathing, as opposed to doing CPR resuscitation. All ventilator gadgets in view of a BVM are basically mechanical arms that crush the sack over and over at a set recurrence. These gadgets can be produced rapidly and on a huge scale, yet since these ventilators are basically siphons that power air into the patient's lungs, they must be utilized for patients under broad sedation or the individuals who are close to death and have nonfunctional lungs. Applying such a gadget to a cognizant patient would prompt a gamble of death through barotrauma, which happens when the human body is presented to an unseemly gaseous tension.

## II. PROPOSED SYSTEM

In this proposed framework, we are estimating the multiparameter, for example, heart beat sensor, SPO2 sensor, internal heat level sensor, arduino and Node-MCU regulator board. All the boundary information is gathered and given to the Node-MCU and afterward refreshed to the IOT page/application. The specialist/client can screen the wellbeing boundaries. ARDUINO is modified in such a way to get the upsides of all sensors like SPO2, Heart thump and internal heat level. On the off chance that any of the qualities are strange, the Nebulizer pack will be turned ON naturally. Once our system predicts the abnormality of human respiration rate, the minimized nebulizer life saving kit is switched ON and produces ventilation automatically without human intervention. To monitor the Heart rate and SPO2 content in their body, we use the MAX30100 sensor which operates on I2C protocol to produce both Heart beat and SPO2 to display in the IOT app/ web page.

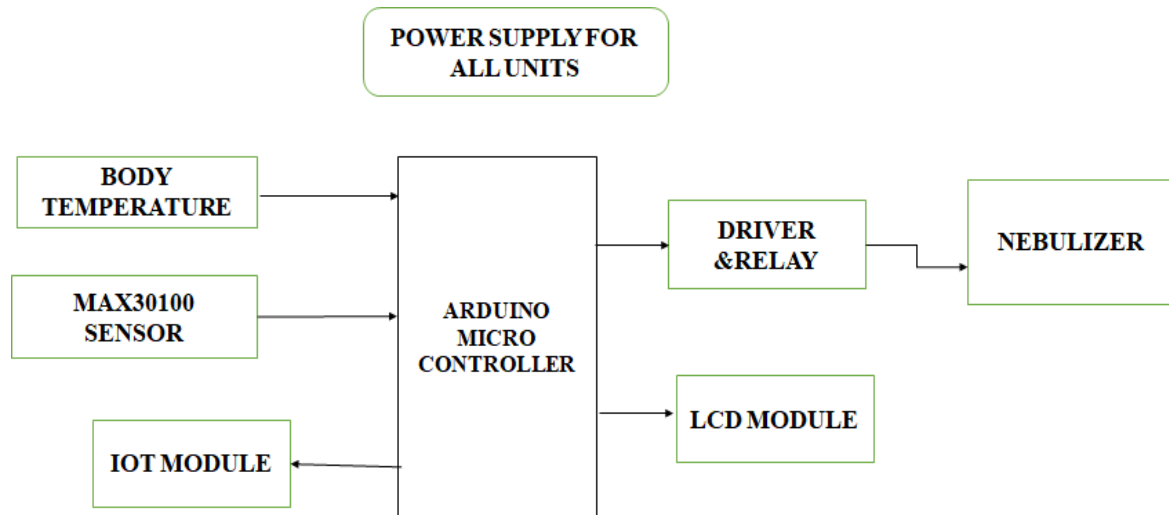

Fig. 1 A sample figure

### III. RESULT AND DISCUSSION

In this project, the ventilator is design to access easily at home without hospitality. It is enabled as when temperature increases, then the nebulizer will be switched on automatically. Actually before if the patient is not able to breath and having low pulse rate, the oxygen will be given to the patient . But it is not possible in all times. The main drawback is that , the availability of bed is low and deaths are happened in this situation. To overcome this, this smart home ventilator will work if heart beat is increased or temperature is increased , by taking heart beat, the spo2 is also checked and then if temperature increased or spo2 is low then the nebulizer will be turned on automatically.

The data of the patient and their heart beat, spo2, temperature is viewed in CAYENNE website Basically in this website the data of the patients are stored up to date. The user who is controlled the website will be provided with user name and password. It will be monitored 24/7 and if the patient is going abnormal, then the nebulizer will turn and when the patient is at normal, then it will be turned off. These are done automatically, so that this model is designed automation and helps the patient from abnormal to normal.

### IV. CONCLUSION

This work proposes the design of a low-cost artificial ventilator in which mechatronic design strategies and manufacturing techniques based on rapid prototyping were implemented. To guarantee the robustness and effectiveness of the proposed design, a robust control scheme based on a sliding mode super-twisting controller is used which allows the proper trajectory tracking control and enables the user to follow the required respiratory profiles using servo motors.

### REFERENCES

- [1] D. J. Baker, *Artificial Ventilation, a Basic Clinical Guide*. Springer, 2016.
- [2] S. Nava and F. Fanfulla, *Non Invasive Artificial Ventilation; How, When and Why*. Springer-Verlag Italy, 2010.
- [3] M. Warner and B. Patel, *Mechanical Ventilation*, 12 2013, pp. 981– 997.e3.
- [4] I. Jenayeh, F. Simon, S. Bernhard, H. Rake, and B. Schaible, “Digital control of a positioning device for a ventilation machine,” in 1997 European Control Conference (ECC), July 1997, pp. 2341–2346.
- [5] A. Das, P. P. Menon, J. G. Hardman, and D. G. Bates, “Optimization of mechanicalventilator settings for pulmonary disease states,” *IEEE Transactions on Biomedical Engineering*, vol. 60, no. 6, pp. 1599–1607, 2013.
- [6] Hoi-Fei Kwok, D. A. Linkens, M. Mahfouf, and G. H. Mills, “Siva: a hybrid knowledge-and-model-based advisory system for intensive care ventilators,” *IEEE Transactions on Information Technology in Biomedicine*, vol. 8, no. 2, pp. 161–172, 2004.
- [7] M. R. Islam, M. Ahmad, M. S. Hossain, M. Muinul Islam, and S. F. Uddin Ahmed, “Designing an electro-mechanical ventilator based on double cam integration mechanism,” in 2019 1st International Conference on Advances in Science, Engineering and Robotics Technology (ICASERT), 2019, pp. 1–6.
- [8] Wen Xin-rong, Wang Wei-hua, You Cai-xia, Xie Lu, Li Meng, and Zhang Guang-de, “Dynamic analysis for slider-crank mechanism of engine at the presence of nonlinear friction,” in 2011 International Conference on Electric

- Information and Control Engineering, 2011, pp. 2125–2128.
- [9] M. Shahid, “Prototyping of artificial respiration machine using ambu bag compression,” in 2019 International Conference on Electronics, Information, and Communication (ICEIC), 2019, pp. 1–6.
- [10] Y. Zhao, R. Qi, and Y. Zhao, “Dimensional synthesis of a slider crank mechanismbased heavy-load positioner,” in 2009 International Conference on Measuring Technology and Mechatronics Automation, vol. 3, 2009, pp. 59–62.
- [11] Chin-Wen Chuang, Chung-Dar Lee, and Chin-Lang Huang, “Applying experiencedself-tuning pid control to position control of slider crank mechanisms,” in International Symposium on Power Electronics, Electrical Drives, Automation and Motion, 2006. SPEEDAM 2006., 2006, pp. 652–657.
- [12] S. Ramos-Paz, F. Ornelas-Tellez, and A. G. Loukianov, “Nonlinear optimal tracking control in combination with sliding modes: Application to the pendubot,” in 2017 IEEE International Autumn Meeting on Power, Electronics and Computing (ROPEC), 2017, pp. 1–6.
- [13] H. K. Khalil, *Nonlinear Systems*. Prentice Hall, 2002.
- [14] W. Perruquetti and J. Barbot, *Sliding Mode Control In Engineering*. Marcel-Dekker, 2002.
- [15] Y. Shtessel, C. Edwards, L. Fridman, and A. Levant, *Sliding Mode Control and Observation*. Birkhauser, 2014.
- [16] M. Guermouche, S. A. Ali, and N. Langlois, “Super-twisting algorithm for dc motor position control via disturbance observer,” in 9th IFAC Symposium of Control of Power and Energy Systems CPES 2015: New Delhi, India, 2015, pp. 43–48.
- [17] J. A. Lewnard and N. C. Lo, ‘ Scientific and ethical basis for social distancing interventions against COVID-19,’ *Lancet Infect. Dis.*, vol. 20, no. 6, pp. 631–633, 2020, doi: 10.1016/S1473-3099(20)30190-0.
- [18] S. Woolhandler and D. U. Himmelstein, ‘ Intersecting U.S. epidemics: COVID-19 and lack of health insurance,’ *Ann. Internal Med.*, vol. 173, no. 1, pp. 63–64, Jul. 2020,doi: 10.7326/M20-1491.
- [19] E. Christaki, ‘ New technologies in predicting, preventing and controlling emerging infectious diseases,’ *Virulence*, vol. 6, no. 6, pp. 558–565, Aug. 2015, doi: 10.1080/21505594.2015.1040975.
- [20] Penang Institute. (2020). Smart City Technologies Take on COVID-19. Accessed: Aug. 2, 2020. [Online]. Available: <https://penanginstitute.org/publications/issues/smart-city-technologies-take-on-covid-19/>
- [21] L. Setti, F. Passarini, G. De Gennaro, P. Barbieri, M. G. Perrone, M. Borelli, J. Palmisani, A. Di Gilio, P. Piscitelli, and A. Miani, ‘ Airborne transmission route of COVID-19: Why 2 meters/6 feet of interpersonal distance could not be enough,’ *Int. J. Environ. Res. Public Health*, vol. 17, no. 8, pp. 2932–2937, 2020, doi: 10.3390/ijerph17082932.
- [22] R. A. Calvo, S. Deterding, and R. M. Ryan, ‘ Health surveillance during covid-19 pandemic,’ *BMJ*, vol. 2020, p. m1373, Apr. 2020, doi: 10.1136/bmj.m1373.
- [23] T. Sharon, ‘ Blind-sided by privacy? Digital contact tracing, the Apple/Google API and big tech’s newfound role as global health policy makers,’ *Ethics Inf. Technol.*, Jul. 2020, doi: 10.1007/s10676-020-09547-x.
- [24] Y. Yin, Y. Zeng, X. Chen, and Y. Fan, ‘ The Internet of Things in healthcare: An overview,’ *J. Ind. Inf. Integr.*, vol. 1, pp. 3–13, Mar. 2016, doi: 10.1016/j.jii.2016.03.004.
- [25] C. F. Pasluosta, H. Gassner, J. Winkler, J. Klucken, and B. M. Eskofier, ‘ An emerging era in the management of Parkinson’s disease: Wearable technologies and theInternet of Things,’ *IEEE J. Biomed. Health Informat.*, vol. 19, no. 6, pp. 1873–1881, Nov. 2015, doi: 10.1109/JBHI.2015.2461555.
- [26] P. A. Laplante and N. Laplante, ‘ The Internet of Things in healthcare: Potential applications and challenges,’ *IT Prof.*, vol. 18, no. 3, pp. 2–4, May 2016, doi: 10.1109/MITP.2016.42.
- [27] P. Pandey and R. Litoriya, ‘ Elderly Care through Unusual Behavior Detection: A Disaster Management Approach using IoT and Intelligence,’ *IBM. J. Res. Dev.*, vol. 64, nos. 1–2, pp. 1–11, 2019, doi: 10.1147/JRD.2019.2947018.
- [28] S. Kang, H. Baek, E. Jung, H. Hwang, and S. Yoo, ‘ Survey on the demand for adoption of Internet of Things (IoT)-based services in hospitals: Investigation of nurses’perception in a tertiary university hospital,’ *Appl. Nursing Res.*, vol. 47, pp. 18–23,Jun. 2019, doi: 10.1016/j.apnr.2019.03.005.
- [29] C. Kotronis, G. Minou, G. Dimitrakopoulos, M. Nikolaidou, D. Anagnostopoulos, A. Amira, F. Bensaali, H. Baali, and H. Djelouat, ‘ Managing Criticalities of e-Health IoT systems,’ *Proc. IEEE 17th Int. Conf. Ubiquitous Wireless Broadband (ICUWB)*, Salamanca, Spain, 2017, pp. 1–5, doi: 10.1109/ICUWB.2017.8251004.
- [30] P. Castillejo, J.-F. Martinez, J. Rodriguez-Molina, and A. Cuerva, ‘ Integration of wearable devices in a wireless sensor network for an E-health application,’ *IEEE Wireless Commun.*, vol. 20, no. 4, pp. 38–49, Aug. 2013, doi: 10.1109/MWC.2013.6590049.
- [31] H. Aly, A. Basalamah, and M. Youssef, ‘ Accurate and energy-efficient GPS-less outdoor localization,’ *ACM Trans. Spatial Algorithms Syst.*, vol. 3, no. 2, pp. 1–31, Aug. 2017, doi: 10.1145/3085575.
- [32] J. K.-Y. Ng, K.-Y. Lam, Q. J. Cheng, and K. C. Y. Shum, ‘ An effective signal strength-based wireless location estimation system for tracking indoor mobile users,’ *J. Comput. Syst. Sci.*, vol. 79, no. 7, pp. 1005–1016, Nov. 2013, doi: 10.1016/j.jcss.2013.01.016.
- [33] S. S. Chawathe, ‘ Indoor Localization Using Bluetooth-LE Beacons,’ in *Proc. 9th IEEE Annu. Ubiquitous Comput., Electron. Mobile Commun. Conf. (UEMCON)*, New York, NY, USA, 2018, pp. 262–268, doi: 10.1109/UEMCON.2018.8796600.

- [34] L. Zhang, J. Liu, and H. Jiang, 'Energy-efficient location tracking with smartphones for IoT,' in Proc. Sensors, Taipei, Japan, 2012, pp. 1–4, doi: 10.1109/ICSENS.2012.6411521.
- [35] [21] Exposure Notifications: Helping fight COVID-19. Accessed: Jul. 20, 2020. [Online]. Available: <https://www.google.com/covid19/exposure-notifications>
- [36] A. Imran, I. Posokhova, H. N. Qureshi, U. Masood, M. S. Riaz, K. Ali, C. N. John, M. I. Hussain, and M. Nabeel, 'AJ4 VIVID-19: AI enabled preliminary diagnosis for COVID-19 from cough samples via an app,' Informat. Med. Unlocked, vol. 20, 2020, Art. no. 100378, doi: 10.1016/j.imu.2020.100378.
- [37] G. Deshpande and B. Schuller, 'An overview on audio, signal, speech, language processing for COVID-19,' 2020, arXiv:2005.08579. [Online]. Available: <http://arxiv.org/abs/2005.08579>
- [38] Cough Vid. Accessed: Aug. 2, 2020. [Online]. Available: <https://coughvid.epfl.ch/about/Breath> for Science. Accessed: Aug. 2, 2020. [Online]. Available: <https://www.breatheforscience.com>
- [39] Cough Against Covid. Accessed: Aug. 2, 2020. [Online]. Available: <https://www.coughagainstcovid.org> [27] COVID Voice Detector. Accessed: Aug. 2, 2020. [Online]. Available: <https://cvd.lti.cmu.edu/>
- [40] FluPhone Project: Understanding Spread of Infectious Disease and Behavioral Responses. Accessed: Aug. 2, 2020. [Online]. Available: <https://www.cl.cam.ac.uk/research/srg/netos/projects/archive/fluphone2>
- [41] E. Yoneki, 'FluPhone study: Virtual disease spread using hagggle,' in Proc. 6th ACM workshop Challenged Netw., 2011, pp. 65–66, doi: 10.1145/2030652.2030672.
- [42] E. Yoneki and J. Crowcroft, 'EpiMap: Towards quantifying contact networks and modeling the spread of infections in developing countries,' in Proc. 1st Int. Conf. Wireless Technol. Hum. Relief, 2011, pp. 233–240, doi: 10.1145/2185216.2185282.
- [43] E. Hernandez-Orallo, P. Manzoni, C. T. Calafate, and J.-C. Cano, 'Evaluating how smartphone contact tracing technology can reduce the spread of infectious diseases: The case of COVID-19,' IEEE Access, vol. 8, pp. 99083–99097, 2020, doi: 10.1109/ACCESS.2020.2998042.
- [44] D. Painuli, D. Mishra, S. Bhardwaj, and M. Aggarwal, 'Fuzzy rule based system to predict COVID19—A deadly virus,' Int. J. Manage. Hum., vol. 4, no. 8, pp. 78–82, 2020, doi: 10.35940/ijmh.H0781.044820.
- [45] R. Sami, F. Soltaninejad, B. Amra, Z. Naderi, S. Haghjooy Javanmard, B. Iraj, S. Haji Ahmadi, A. Shayganfar, M. Dehghan, N. Khademi, N. S. Hosseini, M. Mortazavi, M. Mansourian, M. A. Mananas, H. R. Marateb, and P. Adibi. (2020). A One-Year Hospital-Based Prospective Covid-19 Open-Cohort in the Eastern Mediterranean Region: The Khorshid Covid Cohort (KCC) Study. [Online]. Available: <https://www.medrxiv.org/content/10.1101/2020.05.11.20096727v2>
- [46] E. H. Mamdani and S. Assilian, 'An experiment in linguistic synthesis with a fuzzy logic controller,' Int. J. Hum.-Comput. Stud., vol. 51, no. 2, pp. 135–147, Aug. 1999, doi: 10.1006/ijhc.1973.0303.