

Hybrid Renewable Energy System Control for Maximum Power Extraction and Output Voltage Regulation by Using Fuzzy logic Controller

G Subba Reddy¹, V Anjaneyulu², N Rammohan³

Asst.Professor, Dept. of EEE, NBKRIST, SPSR Nellore, Andhra Pradesh, India-524413¹

Asst.Professor, Dept. of EEE, NBKRIST, SPSR Nellore, Andhra Pradesh, India-524413²

Asst.Professor, Dept. of EEE, NBKRIST, SPSR Nellore, Andhra Pradesh, India-524413³

Abstract: The purpose of this paper is to investigate novel control strategies for hybrid PV/wind control systems. The paper's other result is a description of the attractive controller for the proposed hybrid system. When designing the control process for control systems with limitless energy sources, two primary objectives must be accomplished. Removing the most control from renewable energy sources, such as wind and photovoltaics, is a critical issue. A hybrid double-input (PV/Wind) control system was constructed, simulated in MATLAB, and novel control strategies were assessed in this study. PV panels, wind energy conversion systems (WEC), and a DC/DC converter comprise the proposed control system. The wind control plant model consists of a wind turbine, a PMSG generator, and a rectifier that transfers DC electrical power. PV modules can be joined in a variety of ways to form solar arrays. This page focuses on the replication of PV cells, modules, and clusters. The study concludes with an examination of the execution of the suggested control mechanism.

Keywords: wind energy conversion systems (WEC), hybrid double-input (PV/Wind), Fuzzy logic Controller

I. INTRODUCTION

The utilization of alternative energy sources is becoming increasingly significant in terms of environmental protection and the reduction of petroleum derivatives. In general, wind turbines and photovoltaic (PV) systems are increasingly being employed in a few applications, such as the circulated control era, where they remain isolated or are reconnected to the grid. The most optimistic projections have been surpassed by advancements in wind and photovoltaic (PV) control systems. Anyhow, every sustainable power source has drawbacks of its own. For instance, power generated by the sun and wind is highly dependent on the atmosphere. For instance, it is challenging to transfer PV innovation as a steady source of energy under different light situations or throughout the day. It has been suggested to use a variety of choice vitality sources to address this problem [1]–[3]. The two types of vitality sources sort of complement one other as a result of this process. When properly managed, multisource half-option vitality systems may be able to provide customers with more reliable and high-quality energy than a system that relies on a single asset. Crossover vitality systems have received general study attention as a result of this component. In any event, managing a PV source's nonlinear output characteristics—which vary depending on temperature and sunlight—is a significant challenge.

Proposing a half-and-half PV/wind control system display is the aim of this paper. Extremely important aspects in this model can be altered, which will affect how the power system operates. The proposed show includes PV clusters, a breeze vitality transformation system, and a twofold information DC/DC converter. After obtaining the model, a suitable controller has been planned and various control approaches are considered. The performance of the suggested hybrid system controller has been evaluated at the conclusion.

II. HYBRID PV/WIND SYSTEM SIMULATION

This section summarizes the execution conditions used in the reenacted display and provides basic concepts of the suggested cross-breed scheme. The hybrid system includes PV exhibitions, a breeze vitality change system, and a two-way information DC/DC converter. The following is an explanation of each of these sections.

A. Wind vitality transformation system (WEC)

The following segments of the suggested WEC system, as shown in Fig. 1, include a three-stage diode scaffold, a variable speed wind turbine, and a lasting magnet synchronous generator [4]. Wind energy is converted into torque by the turbine. Through the turbine/generator shaft, the torque is transferred to the generator's rotor.

The mechanical system either accelerates, decelerates, or maintains a constant speed based on the difference between the electrical torque produced by the generator and the mechanical torque produced by the breeze turbine.

In order to support the suggested DC/DC twofold info converter, the generator is connected to a three-stage diode connect converter, which provides corrected three-stage energy. Fig. 2 shows the model that was replicated for WEC in MATLAB/SIMULINK. This model has three-stage rectifiers, a wind turbine, and a PMSG generator. Wind speed, pitch point, and generator speed are the three inputs that the turbine uses. The client can easily adjust the speed to measure the DC output voltage, as shown in Fig. 2. As shown in Fig. 2, the torque generated by the breeze turbine square is proportional to the wind speed and is reinforced to the PMSG obstruction. The PMSG generates the voltage that feeds the rectifier based on this generated torque. Pitch point and generator speed are treated as constant in this article, which also evaluates the effects of varying wind speed.

Figure 3 shows the output control normal for the WEC system. The output control varies due to the DC connect voltage, as shown in the picture. For different speeds, there is a trademark for selective control. The suggested controller sets the DC connect voltage at the specific voltage where the output control becomes noticeably most extreme for each of these characteristics.

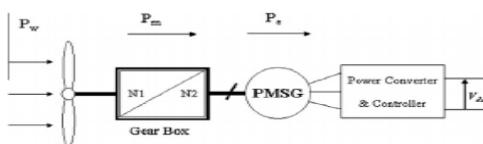


Fig. 1. General schematic of WEC system

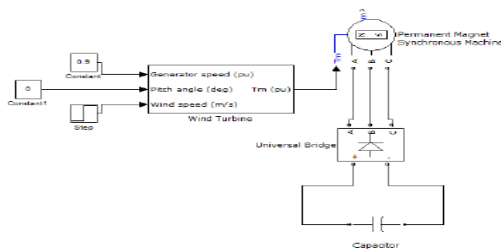


Fig. 2. Proposed WEC system simulated in MATLAB.

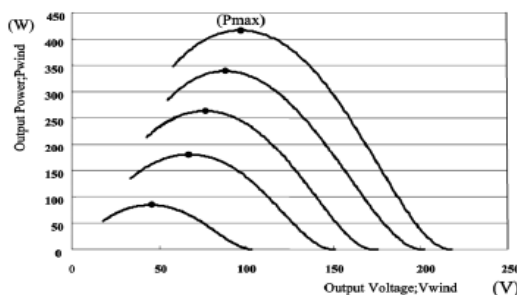


Fig .3. The output power of WEC system.

B. Photovoltaic system

Sun oriented photovoltaic era systems are getting to be progressively essential as a sustainable power source since they offer many favorable circumstances, for example, causing no fuel costs, no contamination, requiring little support, and discharging no clamor, among others. The building piece of PV exhibits is the sun powered cell, which is fundamentally a p– n semiconductor intersection. In the typical working condition, as appeared in Fig 3, the PV cell can be equivalent to a photograph created current source paralleled with a diode and a resistance, at that point in arrangement with a resistance. The non specific forward equal circuit model of PV cell is appeared in Fig. 4. The current– voltage (V– I) normal for a sun powered photovoltaic cell is given by Eq. 1, 2, 3.

$$I = I_{ph} - I_{sc} \left(\exp\left(\frac{q}{AKT}(V + IR_s) - 1\right) \right) - \frac{V + IR_s}{R_{sh}} \quad (1)$$

$$I_{os} = I_{or} \left(\frac{T}{T_r} \right)^3 \exp \left[\frac{q \cdot E_{go}}{Bk} \left(\frac{1}{T_r} - \frac{1}{T} \right) \right] \quad (2)$$

$$I_{ph} = \left[I_{SRC} + K_I (T - T_r) \right] \frac{\Sigma}{1000} \quad (3)$$

In the condition, I is the output current of the cells; V is the output voltage of the cells; I_{ph} is the current caused by light; Ó is the illumination, q is the electron charge; Tr is the reference temperature; T is the temperature of the cells; Sense of self is the silicon taboo band width; K is Boltzmann steady; Rs is the arrangement resistance; Rsh is the parallel resistance; An and B are the fitting steady and An equivalents to B; Ios is the short out current; Ior is the opposite current of the diode; and KI is the temperature coefficient. Among the PV cell's parameters: An, ISRC, RS, Rsh and Ego have an extraordinary effect on the electrical characters and alternate parameters are consistent or have little impact.

With a specific end goal to enhance the extraction effectiveness, diminish the trouble in picking the underlying esteems, and facilitate the ideal imperatives it is smarter to extricate these five parameters, and set alternate parameters with their standard esteems. The consistent parameters of PV modules are appeared in TABLE I. The PV cell's conditions are appeared as (1)- (3). There are three essential sorts of PV cells: mono crystalline, poly-crystalline, and formless. Each of these sorts has distinctive parameters which identify with the arrangement of their PV cells. In this paper a poly-crystalline PV cell has been considered for the half and half system. The parameters of this sort have been appeared in TABLE II. Based on the conditions (1)- (3), and the parameters specified in Tables (1)- (2), a Poly-Crystalline PV module has been reproduced in MATLAB/SIMULINK which is appeared in Fig. 5. The output control qualities of PV exhibits have been appeared in Fig .6. As expressed in the past session, there is a unique voltage for PV clusters to convey greatest power, and this voltage changes in light of temperature and illumination. The control methodology should set the output voltage of PV clusters at this ideal voltage.

C. Twofold information sources DC/DC converter

The proposed multi-input dc– dc converter is the combination of the buck-help and the buck converter. Blends of the multi input dc– dc converter are finished by embeddings the throbbing voltage wellspring of the buck converter into the buck-help converter. All together not to hamper the typical operation of the buck-help converter and to use the inductor for the buck converter, the throbbing voltage wellspring of the buck converter must be arrangement associated with the output inductor. In light of the conduction status of the switches M1 and M2, the multi-inputs dc– dc converter has four operation modes. Fig. 7(a)– (d) demonstrate the proportional circuits for Mode I through Mode IV, separately. At the point when switches M1 or M2 are turned off, diodes D1 and D2 will give a free-wheeling way to the inductor current. In the event that one of the voltage sources fizzles, the other source can in any case give the electric vitality, regularly. Along these lines, this design is extremely appropriate for sustainable vitality applications. Eq.4 demonstrates the connection between input voltages and output voltage.

$$V_o = \frac{D_1}{1 - D_2} \times V_{in1} + \frac{D_2}{1 - D_2} \times V_{in2} \quad (4)$$

In Eq.4 D1 and D2 identify with time span of the power switches M1 and M2, separately. In the proposed hybrid control system, the output voltages of PV exhibits and WEC are considered as Vin1 and Vin2, separately. The info output voltage relationship can be gotten from the consistent state volt-second adjust examination of the inductor. On the off chance that M1 has a more extended conduction time than M2, at that point the proportional operation circuit for one exchanging cycle will take after the succession of Mode I, Mode III, and Mode IV. On the other hand, if M2 has a more drawn out conduction time than M1, the succession moves toward becoming Mode II, Mode III, and Mode IV. In either case, the output voltage can be communicated as Eq. 4.

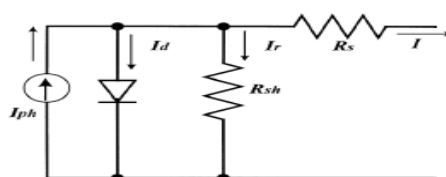


Fig. 4. Equivalent circuit of PV cell.

III. CONTROL SYSTEM OF HYBRID POWER SYSTEM

The proposed controller controls the time term of energy switches of the twofold info DC/DC converter. As the proposed system comprises of two power sources, the control methodology has two degrees of flexibility (DOF). As such, there are a few agreeable control modes, as clarified in the accompanying comments:

- In this mode, the controller removes most extreme power from two power sources. That is to say, controller decides the time span of two power switches in view of MPPT calculations. As the controller has two DOF, the control system can't control the DC output voltage of the DC/DC converter.
- In this mode, the controller removes most extreme power from the WEC system. What's more, the controller decides the DC output voltage of the converter by controlling the time length of the power switch M1. For this situation, most extreme power is separated from the WEC system, while, the PV exhibits fill the need of setting the output voltage to a decided esteem.
- In the last mode, controller extricates greatest power from PV exhibits, while the output voltage is determined to a decided an incentive by controlling the time span of switch M2. In the wake of supplanting the WEC system with PV clusters in the event that two, this case will be accomplished.

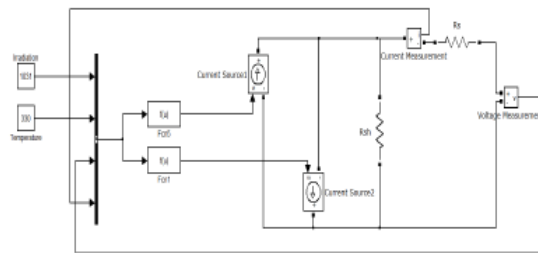


Fig.5.Simulated PV cell in MATLAB/SIMULINK.

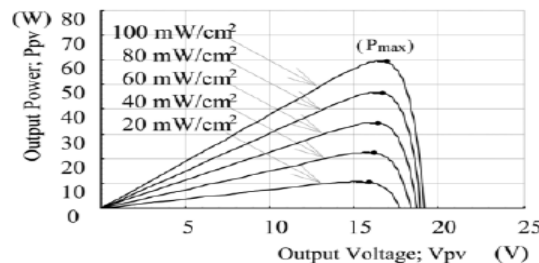


Fig.6. Output power of PV arrays

To plan a controller with the capacity to extricate greatest power and set the output voltage to a decided esteem, two vital issues must be tended to in the accompanying segments: MPPT calculations and control technique.

A. MPPT Algorithms

Distinctive MPPT systems have been proposed in later a long time. Among these procedures, the annoyance and perception strategy is embraced here to satisfy the MPPT calculation in this paper, since it is anything but difficult to actualize and requires less measured parameters. In synopsis, the operation of this procedure is clarified beneath: The target of the P&O strategy is to decide the altering course of the load current. Fig. 8 demonstrates the flowchart of the MPPT calculation with P&O technique for the proposed twofold info converter. Since there are two singular info sources, every single one of them needs an autonomous controller. Be that as it may, both of the controllers can be actualized by utilizing one incorporated controller. Toward the start of the control plot, the output voltage VO and output current IO of the source (either the PV cluster or the breeze turbine) are measured, at that point the output control PO can be as curtailed.

TABLE I. CONSTANT PARAMETERS OF PV MODULE

Parameter	Value
$K/(J/K)$	$1.3806505 \cdot 10^{(-23)}$
$q/(C)$	$1.6 \cdot 10^{(-19)}$
$K_i/(A/K)$	0.0017
$T_r/(K);$	298.15
$I_{or}/(A);$	$0.2287 \cdot 10^{(-6)}$

TABLE II. PARAMETERS OF POLY-CRYSTALLINE PV MODULE

	Poly-Crystalline
$I_{sc}(A)$	8.47
$V_o(V)$	30.10
$E_{go}(V)$	10.03
$I_{SRC}(A)$	8.468
$R_s(\Omega)$	0.661
$R_{Sh}(\Omega)$	498.582
A	60.758

B. Controlling the Output Voltage

To control the output voltage, another controller can control the time length of energy switches. In this paper, a PI controller has been utilized for this. The output of the PI controller is the time length. To encourage this time term to the power switches, a converter is expected to create an intermittent flag with the decided time span. This converter ought to get a recurrence and the decided output voltage as information what's more, deliver the comparing occasional flag. The schematic of the PI controller has been appeared in Fig. 9. The controller in this enhancement should set the output voltage to the decided esteem.

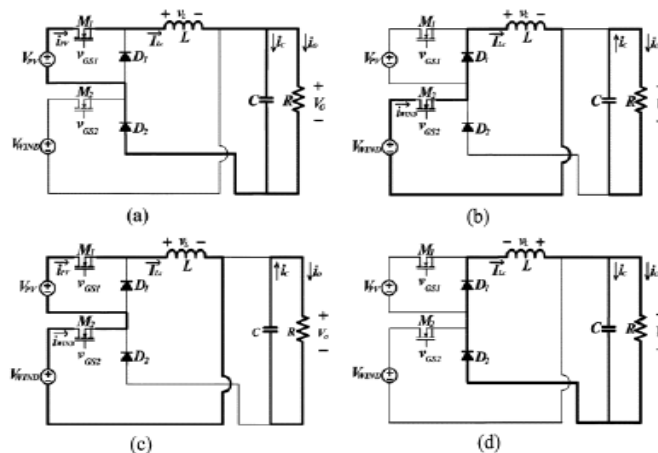


Fig.7. Equivalent circuits for the multi-input dc–dc converter. (a) Mode I. (b) Mode II. (c) Mode III. (d) Mode IV.

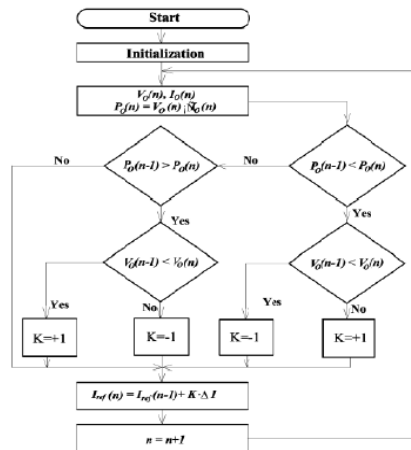


Fig.8. Flow chart of the MPPT algorithm with P&O method.

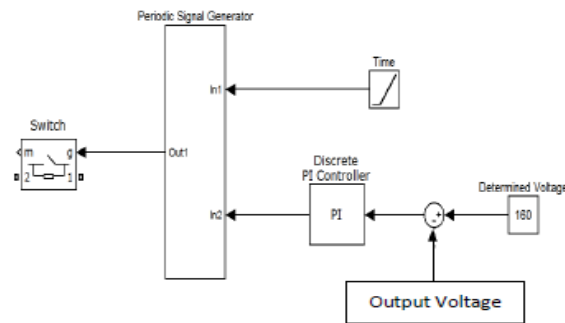


Fig.9. Schematic Model of Output Voltage Controller.

V.FUZZY LOGIC CONTROLLER

- ▶ FLC (Fuzzy Logic Controller) is nothing but set of rules.
- ▶ Fuzzy Logic Controller build by using the GUI(Graphical User Interface) tool and that is provided by the Fuzzy tool Box , It is used to build the system Graphically.
- ▶ There are Five primary GUI tools for building, editing and observing the Fuzzy in Fuzzy tool Box.

There are Five Function, They are

- ❖ FIS Editor
- ❖ MF Editor
- ❖ Rule Editor
- ❖ Rule Viewer
- ❖ Surface Viewer

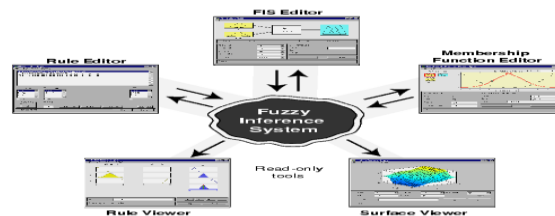


Fig. 6. (c) Fuzzy controller over view.

(A) Fuzzy Interface System:

- ▶ FIS is nothing but Fuzzy Interface System
- ▶ In FIS editor it is shown that Input and Output Variable and we can gives the names to the input and output.
- ▶ We can taken input and output as per our Requirement and there is no limitations for input and output.
- ▶ Between input and output we have a Fuzzy Logic Controller.

- ▶ In that Fuzzy Logic Controller only we can write the rules and that rules are provided as per the paper or Project.

(B) Membership Function Editor:

- ▶ In this we used to defines the shapes of the Membership Functions associated with each variable .
- ▶ In this we can give the names for the MF .
- ▶ We can change the range of X-axis but we can't change the range of the Y-axis.
- ▶ By default it will take as 0 to 1 .
- ▶ For any MF X-axis takes as reference, Y Because we can the range of the X-axis as per our requirement.

(C) Rule Editor:

- ▶ In this rule editor we can edit the rules and we can write the rules behavior.
- ▶ Depends on the rules only the total logic of the FL is controlled.
- ▶ We can able to change the rules here .
- ▶ The number of rules are depends on the number of Membership Functions.

(D) Rule Viewer:

- ▶ After giving rules as per the project we can go for Rule Viewer.
- ▶ In this rule viewer we can able to see how the rules are built.

(E) Surface Viewer:

- ▶ In this surface viewer
- ▶ Rule viewer and Surface viewer are Strictly read only viewer

Advantages:

- The ease to model your reasoning,
- The ability to deal with uncertainty and nonlinearity;
- The ease of implementation;
- The use of linguistic variables.

IV. SIMULATION RESULTS

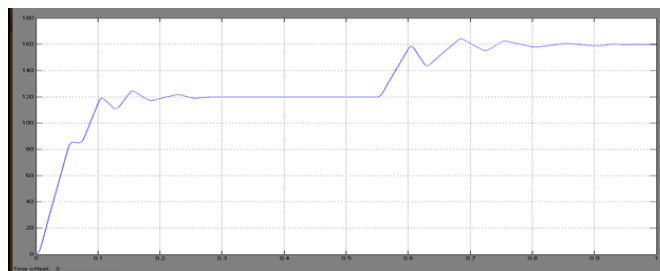
With PI controller:

Fig.10. Output voltage of proposed system after changing of reference voltage

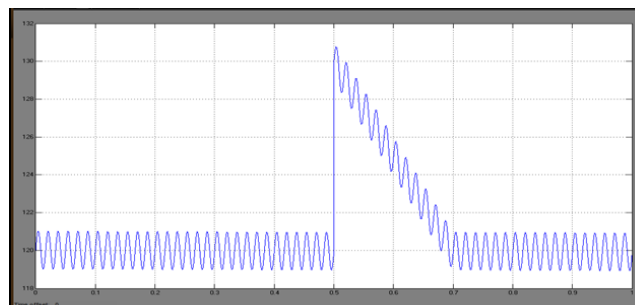


Fig.11. Output voltage of proposed system after changing the amount of irradiation.

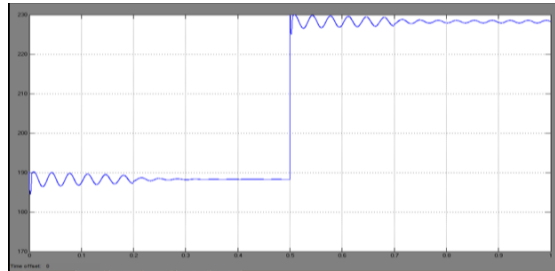


Fig.12.WEC voltage of proposed system after changing the wind speed.

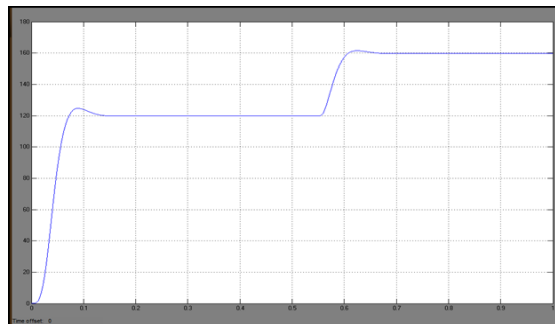
With Fuzzy Logic controller:

Fig.10. Output voltage of proposed system after changing of reference voltage

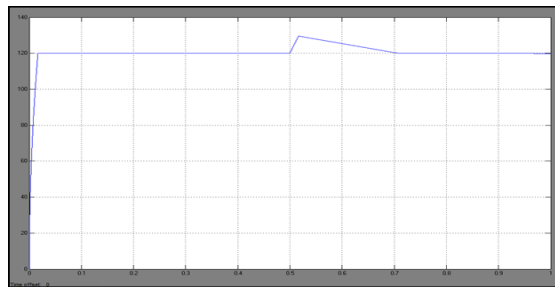


Fig.11. Output voltage of proposed system after changing the amount of irradiation.

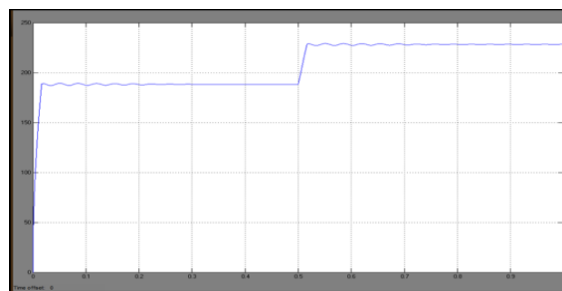


Fig.12. WEC voltage of proposed system after changing the wind speed

V.CONCLUSION

A hybrid PV/wind control system was replicated in this work. PV clusters, a WEC system, and a two-input DC/DC converter are the three key components of the suggested system. Various suitable control approaches for the suggested system were investigated. Retrieving the maximum amount of power from control sources and controlling the output voltage are two essential elements for describing the controller. This study considered these two constituents and their minor components. One of the control approaches was selected, and the reproduction results were taken into consideration, in order to evaluate the performance of the suggested hybrid system. The system reactions, as well as the comparison and hypothetical results, were evaluated under different conditions.

REFERENCES

- [1] Wang, Caisheng and M Hashem Nehrir. "Power management of a stand-alone wind/ photovoltaic/fuel cell energy system." *Energy Conversion, IEEE Transactions on* 23, no.3 (2008):957-967.
- [2] Bajpai, Prabodh and Vaishalee Dash. "Hybrid renewable energy systems for power generation in stand-alone applications review." *Renewable and Sustainable Energy Reviews* 16, no. 5 (2012): 2926-2939.
- [3] Skretas, Sotirios B and Demetrios Papadopoulos. "Efficient design and simulation of an expandable hybrid (wind– photovoltaic) power system with MPPT and inverter input voltage regulation features in compliance with electric grid requirements." *Electric Power Systems Research* 79, no. 9 (2009): 1271-1285.
- [4] Abdullah, M. A., A. H. M. Yatim, C. W. Tan, and R. Saidur. "A review of maximum power point tracking algorithms for wind energy systems." *Renewable and Sustainable Energy Reviews* 16, no. 5 (2012): 3220-3227.